



DEEP CYCLE
SERIES: 5000
MODEL: 4 KS 21P

BATTERY ENGINEERING
WWW.ROLLSBATTERY.COM MADE IN CANADA

BATTERY TYPE: 4 VOLTS

DIMENSIONS:

LENGTH	400 MM	15 3/4 INCHES
WIDTH	238 MM	9 3/8 INCHES
HEIGHT	629 MM	24 3/4 INCHES

WEIGHTS:

WEIGHT DRY	98 KG	216 LBS.
WEIGHT WET	121 KG	267 LBS.

CONTAINER CONSTRUCTION:

CONTAINER: (INNER)	POLYPROPYLENE	TERMINALS:	FLAG WITH STAINLESS STEEL NUTS AND BOLTS
COVER: (INNER)	POLYPROPYLENE - HEAT SEALED TO INNER CONTAINER	HANDLES:	MOLDED
CONTAINER: (OUTER)	HIGH DENSITY POLYETHYLENE		
COVER: (OUTER)	HIGH DENSITY POLYETHYLENE SNAP FIT TO OUTER CONTAINER		

PLATES:

POSITIVE PLATE DIMENSION:

HEIGHT	432 MM	17.000 INCHES
WIDTH	143 MM	5.625 INCHES
THICKNESS	6.99 MM	0.275 INCHES

NEGATIVE PLATE DIMENSION:

HEIGHT	432 MM	17.000 INCHES
WIDTH	143 MM	5.625 INCHES
THICKNESS	4.57 MM	0.180 INCHES

CELLS: 2 **PLATES/CELL:** 21

POSITIVE PLATE DOUBLE WRAPPED WITH SLYVER ENVELOPED WITH HEAVY DUTY SEPARATOR

SEPARATOR:
THICKNESS 3 MM 0.105 INCHES

INSULATION:
GLASS MAT 1 MM 0.020 INCHES

CAPACITY:

CRANK AMPS:		
COLD (CCA)	0°F / -17.8°C	3095
MARINE (MCA)	32°F / 0°C	3869

ELECTROLYTE RESERVE:
ABOVE PLATES 95 MM 3.75 INCHES

RESERVE CAPACITY:
RC @ 25A 3367 MINUTES

20 HR RATE: I 104 50% DOD

	HOUR RATE	SPECIFIC GRAVITY	CAP / AH	CURRENT / AMPS
CAPACITY @	100 HOUR RATE	1.280 SP. GR.	1557	15.57
CAPACITY @	72 HOUR RATE	1.280 SP. GR.	1468	20.39
CAPACITY @	50 HOUR RATE	1.280 SP. GR.	1358	27.16
CAPACITY @	24 HOUR RATE	1.280 SP. GR.	1148	47.8
CAPACITY @	20 HOUR RATE	1.280 SP. GR.	1104	55.2
CAPACITY @	15 HOUR RATE	1.280 SP. GR.	1027	68.4
CAPACITY @	12 HOUR RATE	1.280 SP. GR.	960	80.0
CAPACITY @	10 HOUR RATE	1.280 SP. GR.	916	91.6
CAPACITY @	8 HOUR RATE	1.280 SP. GR.	861	107.6
CAPACITY @	6 HOUR RATE	1.280 SP. GR.	784	130.6
CAPACITY @	5 HOUR RATE	1.280 SP. GR.	740	148
CAPACITY @	4 HOUR RATE	1.280 SP. GR.	684	171
CAPACITY @	3 HOUR RATE	1.280 SP. GR.	618	206
CAPACITY @	2 HOUR RATE	1.280 SP. GR.	530	265
CAPACITY @	1 HOUR RATE	1.280 SP. GR.	375	375



1 STATION RD SPRINGHILL, NOVA SCOTIA CANADA B0M 1X0 1.800.681.9914

REV.2
 Jan-10
 4 KS 21P

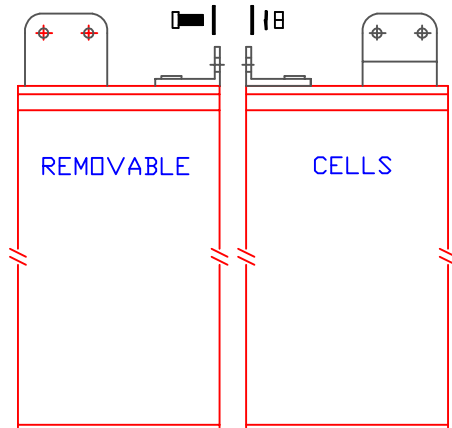

BOLT-ON CONNECTOR ASSEMBLY

2 X 316 SS NUT,
WASHERS, LOCK
WASHER AND BOLT

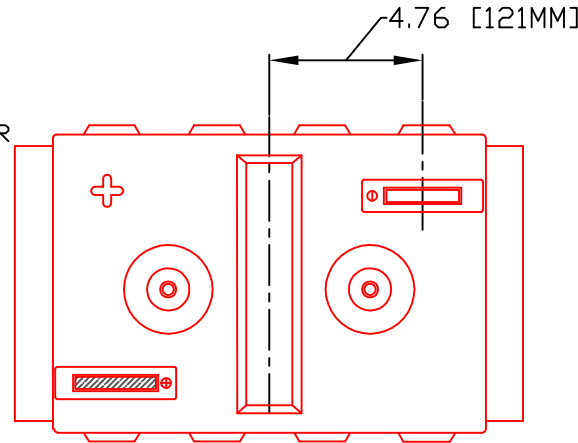

PART NUMBER:

4-KS-21P

WEIGHT WET:

267 LB / 121 KG

WEIGHT DRY:

216 LB / 98 KG

CAPACITY

1,104 AH 20 HR

VOLTAGE:

4 V

OVERALL
DIMENSIONS:

15³/₄" X 9³/₈" X 24³/₄"

MAX HEIGHT WITH
OPTIONAL HYDROCAPS

25.13" / 638 MM

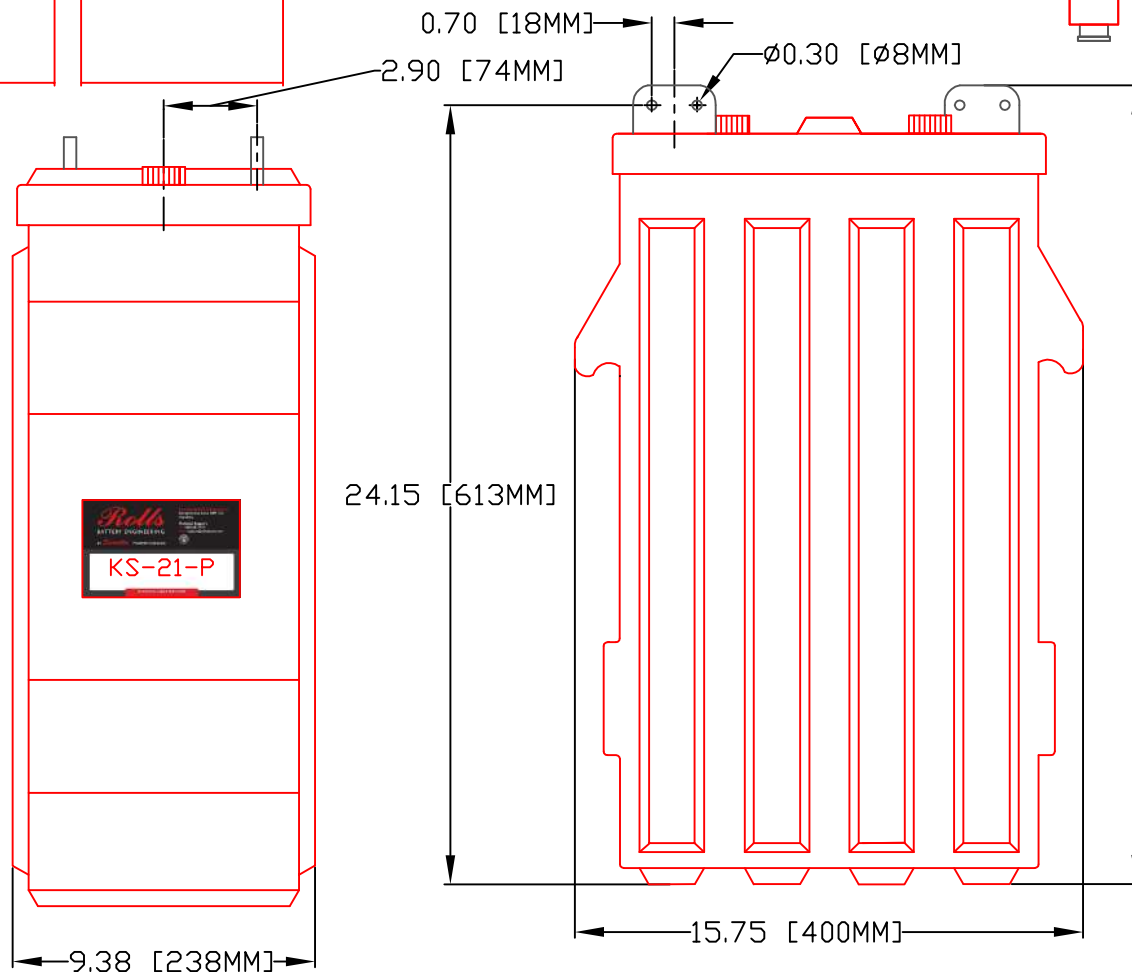

TITLE:

4KS21P

DESCRIPTION:

4V / 2 CELL 21 PLATE (KS) DEEP CYCLE

CONTACT INFO:

WEB: WWW.ROLLSBATTERY.COM
E-MAIL: SALES@ROLLSBATTERY.COM
PHONE: 1-800-681-9914

SCALE: 1" = 6" 1" = 4" JPEG
8.5" X 11" 11" X 17" NOT TO SCALE

Drawn by:

S. WILES

Approved By:

D. SURRETTE

DATE: JAN-2010

REVISION 2.0

DRAWING NO.: DWG 002, BD4KS21P